



हुगली कोचीन शिपयार्ड लिमिटेड  
(भारत सरकार का उद्यम)  
**HOOGHLY COCHIN SHIPYARD LIMITED**  
(A Govt. of India Enterprise)



वसुधैव कुटुम्बकम्  
ONE EARTH • ONE FAMILY • ONE FUTURE

Tender No: HCSL/OPS/SB/TEN/219/2023-24

Dt.- 14.02.2024

**NOTICE INVITING TENDER**

Sealed competitive tenders are invited on behalf of Hooghly Cochin Shipyard Limited (HCSL) from experienced vendors for the under mentioned work, so as to reach the undersigned on or before the date and time mentioned below. Please refer Scope of Work, General Terms and Conditions and Special Terms attached.

Tender No. & date	HCSL/OPS/SB/TEN/219/2023-24, Dt.- 14.02.2024
Scope of work	<b>Procurement of Aluminium Anode for 2200T MPV at Hooghly Cochin Shipyard Limited, Nazirgunge Unit, Howrah (Detailed specification is enclosed separately)</b>
Type of Tender	<b>Two Bid</b>
Cost of tender form	Rs. 500/- (Including GST) (Rupees five hundred only)
Earnest Money Deposit (EMD)	<b>Rs. 10,000/- (Rupees Ten Thousand only)</b>
Last date & time of receipt of tender	06.03.2024 at 15:00 Hrs.
Date & time of opening of technical bid	06.03.2024 at 15:30 Hrs.
Tenure of contract	<b>Within 45 Days</b> (from the date of issuance of Purchase Order).
Officer - in - Charge	Name :Saikat Kumar Biswas Designation: Deputy Manager (Materials) Email :saikat.biswas@hooghlycsl.com Phone No : +91 8250792208  Name : Sreerag .G Designation : Manager (Materials) Email : sreerag.g@hooghlycsl.com Phone No :+91 9916087168

**Tender reference number highlighting due date & time of submission of tender should be clearly indicated on top of the respective envelopes.**

Sealed tenders in Two cover system (Pre-qualification cum Technical and Price Bid) addressed to The DGM (P&O) shall be dropped in the HCSL tender box or courier to **Hooghly Cochin Shipyard Ltd (HCSL), Satyen Bose Road, DaneshSk Lane (PO), Nazirgunge, Howrah, West Bengal, PIN -711109 to reach us on or before the due date and time. E- Mail Quotations are not acceptable.**



Registered Office: Administrative Building, HCSL Premises, Satyen Bose Road,  
P.O. Danesh Shaikh Lane, Nazirgunge, Howrah, West Bengal - 711 109.

+91 (33)-2688 8282 contact@hooghlycsl.com www.hooghlycsl.com

Shipyard: Nazirgunge Unit, Satyen Bose Road, P.O. Danesh SK Lane,  
P.S. Sankrail, Howrah, West Bengal - 711109

+91 (33)-2955 8283

1. **Minimum qualification criteria for participating in the tender will be as follows:**

- i. Successful experience as material supplier in the successful completion of **one (1)** similar material supply of nature and complexity comparable to the proposed material within the last **5 years** from the date of issue of tender document. The value of the Supply of material should not be less than **Rs. 4.45 Lakhs**. (Satisfactory completion certificate from the Client for work done should be submitted along with bid).

Or

Successful experience as material supplier in the successful completion of **two (2)** similar material supplies of nature and complexity comparable to the proposed material supply within the last **5 years** from the date of issue of tender document. The value of each Supply of material should not be less than **Rs.2.78 Lakhs**. (Satisfactory completion certificate from the Client for work done should be submitted along with bid).

Or

Successful experience as material supplier in the successful completion of **three (3)** similar material supplies of nature and complexity comparable to the proposed material supply within the last **5 years** from the date of issue of tender document. The value of each Supply of material should not be less than **Rs.2.22 Lakhs**. (Satisfactory completion certificate from the Client for work done should be submitted along with bid).

**Similar Supply means: Supply of any type of Anode/chemical/acids/alloys for State/Central Govt., Shipyards, MNCs or similar etc. within the respective years ending last day of month previous to one in which applications are invited.**

**Note:** The value of executed works shall be brought to current costing level by enhancing the actual value of works at simple rate of 7% per annum, calculated from the date of completion to the last date of submission of tender document. HCSL will convert all amounts stated in various currencies to equivalent Indian Rupees (INR) based on the exchange rate at the closing of corresponding financial year (31 March) authorized by State Bank of India.

- i. The average Annual Turnover of the bidder should be more than **Rs. 2.78 Lakhs** during the last three preceding years. (Audited Balance sheets showing turnover, Profit & Loss account of the firm for the preceding 03 years (**Financial Year : 2020-21, 2021-22, 2022-23**) should be submitted along with the application for prequalification).
- ii. The Tenderer should enclose copy of Trade License, PAN, GST registration certificate, Income tax returns for last three (**Financial Year : 2020-21, 2021-22, 2022-23**).
- iii. Offers from joint ventures/consortium will not be accepted.
- iv. Net worth of the bidder must be positive as per the latest balance sheet. (MSME/NSIC will get exemptions)



The tender documents can be downloaded from HCSL/CSL website <http://hooghlycsl.com/www.cochinshipyard.in>. The tender documents are available on above mentioned link. All corrigenda, addenda, amendments and clarifications to this tender will be hosted in the website [www.cochinshipyard.in](http://www.cochinshipyard.in) or <http://www.eprocure.gov.in>. Bidders shall keep themselves updated with all such developments till the last date and time of submission of tender.

**Tender administration:** Tender procedure/administration/evaluation including correspondences and awarding of contract will be done M/s. Hooghly Cochin Shipyard Limited, Howrah, West Bengal.

Officer - in - Charge for the above work:

Name: Saikat Kr. Biswas  
Designation: Deputy Manager (Materials)  
Email: [saikat.biswas@hooghlycsl.com](mailto:saikat.biswas@hooghlycsl.com)  
Phone No: 8250792208

Name: Sreerag .G  
Designation: Manager (Materials)  
Email: [sreerag.g@hooghlycsl.com](mailto:sreerag.g@hooghlycsl.com)  
Phone No: +91 9482608957

Only for query in connection with material certificates, make & grade (Please contact the below person)

Name: Samrat Basu  
Designation: Senior Manager (Mech.)  
Email: [samrat.basu@hooghlycsl.com](mailto:samrat.basu@hooghlycsl.com)  
Phone No: +91 9094362621

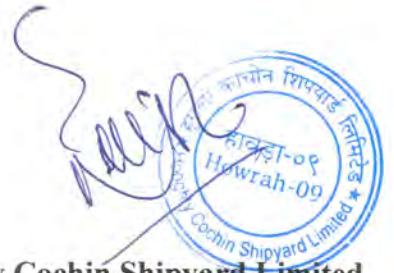
A handwritten signature in blue ink is written over a circular blue stamp. The stamp contains the text 'হাওড়া-০৯' (Howrah-09) and 'Hooghly Cochin Shipyard Limited' around the perimeter.

**For Hooghly Cochin Shipyard Limited**

**TABLE OF CONTENTS**

<b>Sl. No.</b>	<b>Description</b>	<b>Annexure</b>
1	Scope of Supply & Important Instruction	1
2	Technical Specification	2
3	Price Bid Format	3
4	General Terms & Conditions	4
5	Special Terms & Conditions	5
6	Techno-Commercial Checklist	6
7	Vendor details	7
8	NEFT Mandate Form	8
9	List of deviation	9
10	Form of Bank Guarantee towards EMD	10
11	Form of Bank Guarantee towards SD	11
12	Form of Self Declaration	12
13	Form of Legal Cases	13

Signature and Seal of the Bidder(s)

For **Hooghly Cochin Shipyard Limited**



**A) SCOPE OF SUPPLY**

Procurement of Aluminium Anode for 2200T MPV (**200 Nos.**), for Hooghly Cochin Shipyard Limited, Nazirgunge Unit, Howrah (Detailed specification is enclosed separately).

**B) IMPORTANT INSTRUCTION**

*Suppliers shall take notice on the following points for its strict compliance*

As the items are critically required, non-compliance of any of the following points will invite disqualification of the submitted offer without any further communication/ notice from this office in this regard.

- I. For the consideration of the offer and its price bid opening, suppliers should ensure the compliance of following points (which are mandatory in line with this particular tender) as stipulated in the general terms and conditions of enquiry and techno-commercial check list herewith.
1. Pre-Qualification Criterion.
  2. Payment of Tender fee.
  3. EMD/ Bid Security Declaration.
  4. Liquidated damage
  5. Payment terms
  6. Validity of offer
  7. Security deposit
  8. Guarantee
  9. Material test certification from the competent authority (If Applicable)
  10. Risk purchase
  11. Make and Gradeof offered item.
  12. Submission of relevant catalog for offered material (if applicable)
  13. Self-certified copy of MSE/NSIC certificate **in relevant** field, if applicable.
  14. Price bid to be submitted in the price bid format attached at **Annexure-3**.
  15. Un-priced bid to be submitted along with techno commercial bid with details like percentage of taxes & duties applicable & details like quoted/nil/included to be mentioned for each line item.
  16. The tender should enclose copy of PAN, GST registration certificate, Income tax returns for **last 3 Financial Year: 2020-21, 2021-22, 2022-23**. (A copy of the same shall be submitted along with the application for issue of tender document)

**II. MSME/NSIC BENEFITS:**

**A.** The following benefits are extended for all the firms who are registered with District Industries Center and come under the category of Micro and Small Enterprises holding a valid Entrepreneurs Memorandum (EM) part ii certificate or Udyog Aadhaar Certificate. However, in order to avail the benefits as per public procurement policy for MSME's orders, 2012, all MSE bidders are required to declare their Udyog Aadhaar Memorandum (UAM) number in Central Public Procurement Portal (CPPP) compulsorily.

- Tender Forms Shall Be Issued Free of Cost.
- Payment of earnest money deposit (EMD) is exempted.



• The list of items published as part of MSME order dated 23rd March 2012 {currently 358 items} shall be procured exclusively from MSE firms only.

**B.** For all firms who are registered with National Small Industries Corporation (NSIC) and come under Micro and Small Enterprises holding a valid NSIC certificate, the below benefit also extended in addition to above.

Waiver of security deposit (SD) for the performance of the contract (3% of the order value by the way of bank guarantee till the supplies are completed), up to financial limit as mentioned in NSIC certificate. However, to ensure performance of the item during the guarantee period a performance bank guarantee (PBG) (3% of order value by the way of bank guarantee) to be submitted by the firm as applicable.

**C.** This tender shall be based on MSME order dated 23rd march 2012, pertaining to public procurement policy.

**D.** When supply/service as per tender is divisible in nature, MSE's within price band of L1+15 percent shall be allowed to supply a portion up to 25% of requirement by bringing down their price to L1 price where L1 is non MSE's. If multiple vendors satisfy the above condition, requirement shall be divided equally. In this scenario, preference shall be given to SC/ST vendors to such an extent that they are allowed to supply minimum 4% out of the 25% in line with the aforementioned MSME order. SC/ST vendors shall submit a valid certificate from district industries center / NSIC, for qualifying in the above criteria.

**E.** In the case of tender item non-splitable or non-divisible, MSE's quoting price band L1 + 15% (in the ascending order) may be awarded full/ complete supply of total tendered value to MSE's by bringing down their price to L1 price where L1 is non MSE's, considering spirit of policy for enhancing the government procurement from MSE's.

**F.** Traders are exempted from the benefits from Public Procurement Policy, for MSEs Order, 2012. As mentioned in O.M. No. 5/2(2)/2021-E/P & G/Policy dated 02.07.2021, Retail and Wholesale traders can register on Udyam Registration Portal for the purpose of Priority Sector Lending (PSL) only. Procurement under this bid is reserved for purchase from Micro and Small Enterprises whose credentials are validated online through Udyog Aadhaar for that product category.

**If the bidder wants to avail the reservation benefit, the bidder must be the manufacturer of the offered product in case of bid for supply of goods. Traders are excluded from the purview of Public Procurement Policy for Micro and Small Enterprises.**

III. It is reiterated that offers submitted without compliance of any one of the aforesaid points will not be considered for its evaluation and summarily be rejected on commercial background without any further clarification/ notice/ communication in this regard from M/S Hooghly Cochin Shipyard Ltd., even though the offer is technically acceptable.

For Hooghly Cochin Shipyard Limited



## TECHNICAL SPECIFICATION

### 1. Supply of Aluminium Anode(with metallic leg for fitment): 200 nos.

The anodes shall be bright and unpainted and the steel under these shall be painted adequately.

### 2. Documents to be submitted along with the supply (cost for the same, if any, shall be on bidder / manufactures responsibility).

- Manufactures certificate of Inspection & Test records
- Report of Analysis & composition
- Material specification with current capacity of anodes.
- Life of anode to be 5 Years.

### Tender Specification Reference as below

### 3. Sacrificial anode for Cathodic Protection

a) Sacrificial anode Cathodic Protection System: Anode system (Aluminium anodes) shall be installed as per IS8062/1977 or equivalent IRS standard and the same shall be designed for a life of not less than 5 (Five) years. The anodes shall be fitted with doubler plates. External anodes shall be welded. The anodes shall be bright and unpainted and the steel under these shall be painted adequately.

#### Welded Anode Detail

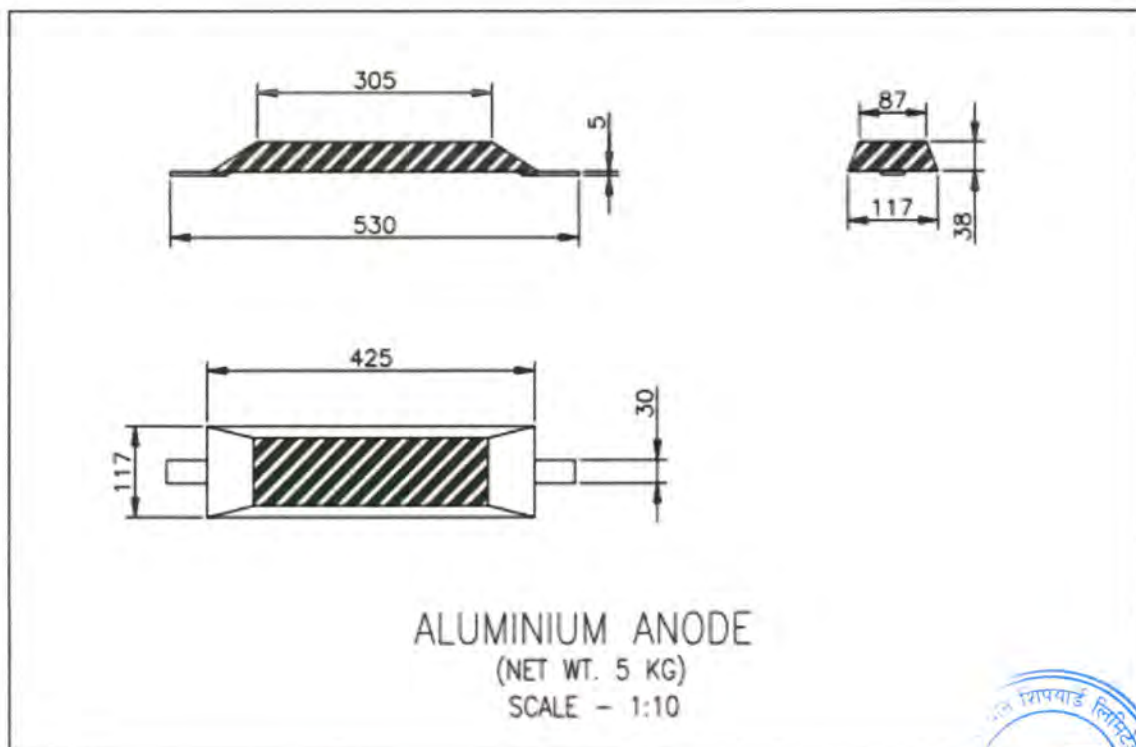

### CALCULATION REQUIRED FOR ANODE REQUIREMENTS

HULL WETTED SURFACE AREA - 1536 M<sup>2</sup>  
WETTED SURFACE AREA OF SKEG - 12 M<sup>2</sup>  
SURFACE AREA OF RUDDER BLADE - 18 M<sup>2</sup>  
SEA WATER CURRENT DENSITY - 25 mA/M<sup>2</sup>  
ANODE MATERIAL - ALUMINIUM  
CAPACITY OF ALUMINIUM - 2651 Ah/kg  
WEIGHT OF EACH ANODES - 5KG  
DESIGN LIFE - 5 YEARS

#### TOTAL CURRENT REQUIRED

$$\text{TOTAL CURRENT REQUIRED} = \frac{\text{AREA} \times \text{CURRENT DENSITY}}{1000}$$

1. FOR HULL =  $\frac{1536 \times 25}{1000} = 38.4 \text{ A}$
2. FOR SKEG =  $\frac{12 \times 25}{1000} = 0.3 \text{ A}$
3. FOR RUDDER BLADE =  $\frac{18 \times 25}{1000} = 0.45 \text{ A}$
4. FOR SEA-CHEST =  $\frac{6 \times 25}{1000} = 0.15 \text{ A}$
5. FOR TRANSOM =  $\frac{5 \times 25}{1000} = 0.125 \text{ A}$

$$\text{TOTAL WT. REQUIRED FOR ANODE} = \frac{\text{CURRENT} \times \text{DESIGN LIFE} \times 8760}{\text{CAPACITY OF ALUMINIUM} \times \text{UTILISATION FACTOR}}$$

1. FOR HULL =  $\frac{38.4 \times 5 \times 8760}{2651 \times 0.8} = 793 \text{ KG}$
2. FOR SKEG =  $\frac{0.3 \times 5 \times 8760}{2651 \times 0.8} = 6 \text{ KG}$
3. FOR RUDDER BLADE =  $\frac{0.45 \times 5 \times 8760}{2651 \times 0.8} = 9 \text{ KG}$
4. FOR SEA-CHEST =  $\frac{0.15 \times 5 \times 8760}{2651 \times 0.8} = 3 \text{ KG}$
5. FOR TRANSOM =  $\frac{0.125 \times 5 \times 8760}{2651 \times 0.8} = 3 \text{ KG}$

#### TOTAL NO. OF ANODE PROVIDED

1. FOR HULL = 793 + 10% = 872 KG = 174 NOS.
2. FOR SKEG = 6 + 10% = 7 KG = 1 NO. (2 NOS. FOR EACH SIDE)
3. FOR RUDDER BLADE = 9 + 10% = 10 KG = 2 NOS.
4. FOR SEA-CHEST = 3 + 10% = 3 KG = 1 NO. (2 NOS. FOR EACH SIDE)
5. FOR TRANSOM = 3 + 10% = 3 KG = 1 NO. (2 NOS. FOR EACH SIDE)





Price Bid Format

Procurement of Aluminium Anode for 2200T MPV at Hooghly Cochin Shipyard Limited, Nazirgunge Unit, Howrah							
Sl. No	Material Description (Scope of Supply)	Quantity (in Nos.)	UOM	Unit Rate (INR)	Amount (without GST) (INR)	GST Amount (INR)	Total Amount (Including GST) (INR)
-	-	(A)	-	(B)	(C=A*B)	(D)	(E= C+D)
1	AL Anode (with metallic leg for fitment) Refer drawing & calculation in Annexure 2 of tender document.	200.	Nos.				
2	Total Amount without GST (INR)						
3	Total GST Amount (INR)						
4	Total Amount Including GST (INR)						
5	Total Amount Including GST (IN WORDS)						

**NOTE:**

1. Quotation for all line items is mandatory. Partially quoting for few line items shall result in rejection of the bid.
2. Quoted rate should be inclusive of all charges considering entire Scope of Work, Technical Specification and Certification. Freight Charge, if any, should be included in Unit Rate and not to be mentioned as a separate line item.
3. Price Bid to be submitted strictly as per format. Modifying the format will result in rejection of the bid.
4. L1 Bidder will be evaluated based on the combined cost of all the items excluding GST.
5. Un-priced Price bid as per **Annexure-3** to be submitted along with techno commercial bid with details like percentage of taxes & duties applicable & details like **quoted/nil/included** to be mentioned for each line item.

**Signature and Seal of the Bidder(s)**

**GENERAL TERMS AND CONDITIONS**

1. Tenderers are to carefully go through the terms and conditions and the technical specification of the items for which offers are called for.
2. Offers are to be furnished in duplicate and should be free from overwriting. Corrections and additions, if any, must be attested. Incomplete/ambiguous offers are likely to be rejected.
3. Offer shall be submitted in the prescribed form to M/s Hooghly Cochin Shipyard Ltd (HCSL), Nazirgunge Works, Satyen Bose Road, P. O. Danesh Sk. Lane, Howrah - 711 109, West Bengal at the designated tender box and has to be addressed to The Deputy General Manager (Projects & Operations).
4. All applicable taxes, duties, transportation, delivery, etc at HCSL Nazirgunge, should be included in the rate quoted, unless specified otherwise. HCSL reserves the right for the deduction of taxes and duties as applicable from the bill or invoice.
5. Indigenous tenderers should quote prices for delivery of materials at HCSL store (**Address:** Hooghly Cochin Shipyard Ltd (HCSL), Satyen Bose Road, Danesh Sk. Lane (PO), Nazirgunge, Howrah, West Bengal, PIN - 711109). Insurance for transit shall be arranged by the vendor.
6. Loading, transportation and all sundry expenses etc. shall be at supplier's scope. Material unloading scope at Hooghly Cochin Shipyard Ltd, Nazirgunge Unit is under HCSL Account.
7. In case of rejection, the rejected item shall be taken back by the supplier from HCSL site and replace the same with new, without any additional cost. The replacement has to be completed within 72 hours from the date of intimation.
8. Final amount shall be calculated on the basis of actual quantity received against certified invoice by HCSL executing officer/store officer.
9. HCSL has the right to withdraw the tender in partial or full during the course of this tender.
10. Bidders to note that no advance payment will be made by HCSL against work order issued.
11. Bidders can contact Officer-in-charge of the work which is indicated in the Tender Notice for any clarification before submitting the offer. If clarifications/details are not obtained before the offer is submitted, no claim on this account will be admitted.
12. **Delivery Period is 45 days from the date of issuance of PO.**
13. Acknowledge the receipt and acceptance of purchase order/Work order by signing and returning a copy of the same within three days of receipt of the same. If the acknowledgement is not received, it will be presumed as accepted.
14. Delivered material weight will be re verified by HCSL Weigh Bridge, if required. Weighment at HCSL will be Final.
15. Subcontracting is not allowed.



## 16. PAYMENT TERMS:

100% after delivery and final acceptance of material at HCSL store. Payment shall be released against invoice certified by store officer/executing officer and other mandatory documents, as per purchase order and on furnishing the following documents.

- i) GST Invoice in Triplicate.
  - ii) Packing List.
  - iii) Security Deposit.
- a. Payment shall be made as per actual quantity of supply and at the accepted rates.
  - b. Supplied material to be verified defect free, and to be accepted.
  - c. Payment towards all on account bills shall be normally paid within 30 working days from the date of receipt of error free certified bill by the Officer of HCSL as far as possible.
  - d. To avoid non-acceptance, ensure to indicate P.O.NO, ITEM NO, PART NO. AND VENDOR CODE in the Delivery Challan accompanying the material.
  - e. i) The invoice shall be compliant with GST Law. (ii) GST liability is to be discharged and ensure filing of outward supply details on GSTN portal within timeline prescribed. (Covered under GST Terms and Condition at (B)) (iii) Any debit note/supplementary invoice if any, is to be raised within September month following the respective Financial year or filing of annual return by HCSL, whichever is earlier. (iv) Any loss of tax credit due to the reason attributable to supplier shall be recovered from supplier along with Applicable interest and penalty.
  - f. Payment mode shall be Electronic Clearing System (ECS)/cheque /NEFT/ /LC/CAD/TT-as mutually agreed in line with above standard payment terms. Variations from standard terms, if any, shall be appropriately loaded for tender comparison purposes for arriving the lowest bid. Bank charges (including LC charges, if any) inside India will be to HCSL account and outside India to supplier's account (In the case of import shipments). The charges for LC amendment, if any, shall be borne by the parties by whom the same is attributed/ necessitated.
  - g. For deviation in Payments terms from HCSL standard terms, if any, aforesaid interest will be loaded on quoted item prices, for tender comparison purposes for arriving lowest bid.

17. Materials offered shall confirm to HCSL specification.

**18. Force Majeure condition:** - Should failure in performance of the contract or part thereof arise from war insurrection, restraint imposed by Government, Act of Legislature or other Statutory Authority or illegal strike, riot, legal lock-out, flood, fire, explosion, act of God or any inevitable or unforeseen event beyond human control which may be construed as reasonable ground for an extension of time, HCSL may allow such additional time as is mutually agreed, to be justified by the circumstances of the case. The occurrence/cessation of force majeure situation is to be informed with documentary evidence within 15 days from the date of occurrence/cessation.

**19. Liquidated Damage:** -In case of delay in supply of ordered materials beyond the stipulated delivery period, which is not attributable to HCSL, supplier is to pay Liquidated Damages (and not by way of penalty) a sum equivalent to ½% (half percent) per week or part of the week of the total basic price in case of Machinery/Equipment and of basic price of materials delayed in all other cases, subject to a maximum of 10% of the total basic price of undelivered material/10% of total basic price of machinery/equipment (Total basic price is the order value excluding freight, taxes, other charges etc.). Further GST will be applicable upon LD and the same also will be deducted along with LD. However, LD applicability is without prejudice to HCSL right to terminate contract for delayed delivery or other actions as per Risk Purchase clause:



**20. Risk Purchase:**

If the Contractor fails to commence the work as per the instruction of Officer in Charge or violate any of the terms and conditions of the purchase order, HCSL shall have the following rights.

- a) To cancel the order partially or full with 15 days' notice and to forfeit the security deposit, if any.
- b) To impose tender holiday for the vendor for an appropriate period as decided by HCSL.
- c) To initiate alternate procurement action at the risk and cost of the supplier.
- d) This Risk Purchase clause is applicable only in the case of total order/contract value(excluding taxes and duties) is Rs.20 lakhs and above (or equivalent foreign currency).
- e) Cases of value less than 20 lakhs will be addressed by serving appropriate caution/ warning notice to the firm.

**21. Warranty/ Guarantee:** -The product supplied shall be guaranteed for satisfactory performance for 12 months from the date of commissioning or 18 months from the date of delivery of items whichever is earlier against faulty design, defective materials and bad workmanship. Supplier should supply and install free of cost immediately any part found to be defective for the above reasons within the guarantee period. The Services shall be guaranteed for a minimum period of 06 months from the date of successful commissioning/final acceptance.

Further, replaced/repaired items shall be guaranteed for 12 months from date of repair/replacement.

**22. MSEs, Startups and Make in India:**

Local Suppliers (Make In India), MSE firms and Start-ups will be eligible for various Relaxation in pre-qualification criteria and other Benefits as per orders promulgated by Government of India. Bidders are advised to refer the details of various Benefits and Relaxations in pre-qualification criteria as published at CSL website ([www.cochinshipyard.com](http://www.cochinshipyard.com)) under the Tenders tab, for further reference.

**23.** Suppliers are allowed to depute their authorized representative to be present at the time of opening of the Tender.

**24. Indian Agent** - Hooghly Cochin Shipyard Ltd. (HCSL) is a 100-percentage subsidiary of Cochin Shipyard Ltd (CSL) under ministry of shipping, Govt. of India Enterprise and prefers to deal directly with the supplier. However, if the supplier appoints an Indian Agent to deal with HCSL, the commission payable by the supplier to such an agency shall be intimated. The Indian agent shall be enlisted with Director General of Supplies and Disposals under the compulsory registration scheme of Ministry of Finance. "If manufacturer's effect supplied through Agents only, authorization in writing from manufacturers in favor of the Agent for supply to HCSL shall be furnished. If Indian Agent submits offers on behalf of foreign manufacturers, copy of the Agency Agreement between them and their mutual interest in the basis to be furnished. In case where an Agent participates in a tender on behalf of a foreign manufacturer with specific authorization from the manufacturer, he should not quote on behalf of another foreign manufacturer along with the first manufacturer in a subsequent/parallel tender for the same item. In other words, one Agent cannot represent two suppliers or quote on their behalf in a particular tender. "

**25. Jurisdiction:** All questions, disputes or difference arising under, out of, or in connection with contracts shall be subjected to the exclusive jurisdiction of the Courts at Kolkata, India.

**26. Cost of EMD (Earnest Money Deposit):** Tenderers shall deposit an amount of **Rs. 10,000/- (Rupees Ten Thousand only)** as Earnest Money Deposit (EMD) along with the tender.



- a) The EMD can be remitted in the form of Demand Draft (DD) / Banker's Cheque / Fixed Deposit Receipt (FDR)/ Bank Guarantee drawn in favour of 'Hooghly Cochin Shipyard Ltd. payable at Kolkata and shall be valid for a period of 6 (Six) months from the due date of opening of Techno-commercial Bids from any Nationalized/ Scheduled Bank or paid online through e-gateway of -

UNION BANK OF INDIA  
SHIBPPUR BRANCH  
ACCOUNT NO: 756905010000104  
IFSC CODE: UBIN0575691

- b) EMD furnished by all contractors except the lowest tenderer will be released after issuing work order and submission of SD and its acceptance by the contractor to whom the work is awarded.
- c) EMD of the successful tenderer will be refunded after remittance of the security deposit and execution of the agreement.
- d) EMD deposited with the Client will be forfeited,
- i) if a bidder withdraws or modifies his bid during the period of validity specified or
- ii) if the successful bidder fails within the time limit to sign the agreement document or fails to furnish the required security deposit.
- iii) Request for enhancement in the quoted rates or bringing in new conditions after tender opening or unnecessary delayed acceptance of the order / commencement of work / submission of Security Deposit.
- e) The relevant documents pertaining to the EMD should be enclosed in a separate sealed cover, super scribing the Tender Notice No. with Date in Cover-1. TENDERS RECEIVED WITHOUT EMD WILL NOT BE CONSIDERED AT ALL FOR FURTHER EVALUATION.

27. Cost of Tender Form: **Rs. 500/- (Including GST)** shall be submitted in the form of Demand Draft, in favour of HCSL Ltd., payable at Kolkata. TENDERS RECEIVED WITHOUT TENDER FEE WILL NOT BE CONSIDERED AT ALL FOR FURTHER EVALUATION.

**28. Security Deposit/ Warrantee Bank Guarantee:**

a.i) The successful bidder shall remit a security deposit of 3% of the total order value (excluding taxes, duties) in the form of demand draft drawn in favour of Hooghly Cochin Shipyard Ltd towards the satisfactory performance of the contract, if an order is placed on them. Alternatively, a Bank Guarantee equivalent to above % of the total order value (excluding taxes, duties) as per HCSL format from an International Bank as per approved list of banks available in CSL website (for overseas supplier) & Scheduled Indian bank for Indian supplier is to be submitted, if an order is placed towards satisfactory performance of the contract.

a.ii) The Bank Guarantee /DD as above should be valid for item delivery at yard plus 90 days. Fixed Deposit Receipt (for equivalent amount of Security Deposit/WBG required as per tender) in lieu of bank guarantee is also acceptable. Fixed Deposit Receipt shall be in the name of supplier with lien marked in favor of Hooghly Cochin Shipyard Limited, Kolkata.

a.iii) The above SD/WBG is required or applicable only when the total order value (excluding taxes and duties) is Rs.20lakhs and above (or equivalent foreign currency).



b) If the bidder is not agreeable to submission of SD/ warrantee bank guarantee as per HCSL general terms and conditions of enquiry, HCSL reserves the right to reject the offer at our discretion or 3% of total order value (excluding taxes and duties) will be added to the quoted price for tender comparison/ evaluation purpose on case to case basis for arriving the lowest bid. However, in cases where total quoted value is less than 20 lakhs, (ie split order etc) and the order value of entire tendered items is more than Rs 20.0 lakhs, the aforesaid loading will be applied on individual items in following cases.

- The bidder has not quoted for entire tendered quantity
- HCSL has technically / commercially rejected a few items in the tender

c) SD to be submitted within 14 Days of receipt of order from yard.

d) Format of bank guarantee along with enquiry to be agreed, in general.

e) Mode of receipt of bank guarantee is strictly through SWIFT mode from supplier bank to HCSL designated bank (for overseas bidders)

29. Supplier should depute only persons who are entitled for exemption for income tax in India or any site work. In case the supplier does not depute such persons, the tax liability will be to supplier's account.
30. Packing Material should be eco-friendly.
31. Supplier should follow the statutory requirements of products offered.
32. After submission of tender, no unsolicited correspondence will be entertained.
33. Hooghly Cochin Shipyard Limited does not bind itself to accept the lowest or any tender but reserves to itself the right to reject any or all or a part of any tender at its discretion.
34. In any case of the above conditions is not acceptable to the tenderer, it should be specifically indicated in the tender failing which it will be presumed that all the terms and conditions are acceptable.
35. In a tender, either the Indian Agent on behalf of the Principal/OEM or Principal/OEM itself can bid but both cannot bid simultaneously for the same item/product in the same tender.
36. If an agent submits bid on behalf of the Principal/OEM, the same agent shall not submit a bid on behalf of another Principal/OEM in the same tender for the same item/product.
37. Conditional discounts, if any, will not be reckoned for tender evaluation/ comparison purposes. However, the same will be considered while placement of purchase orders if the bidder turns out to be L1.
38. After submission of tender, no unsolicited correspondence will be entertained.
39. Deviations, if any, in the offer submitted from that of the tender enquiry in any form, should be clearly furnished in a separate document titled as "List of Deviations", failing which it will be presumed that all the terms and conditions are acceptable.
40. Public Procurement Policy initiatives of Govt. of India, pertaining to MSME's, startup etc. as per CSL website ([www.cochinshipyard.in](http://www.cochinshipyard.in)) shall be applicable for this tender.

For Hooghly Cochin Shipyard Limited

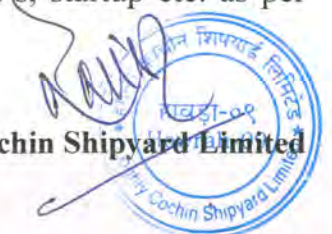

**Tender conditions for Restriction of bidders sharing land border with India vide Office memorandum dt 23.7.2020 Order Public Procurement no 1 dt 23.7.2020, Order no 2 dt 23.7.2020, Order no 3 dt 24.7.2020 and amendments issued by GOI time to time.**

<b>A</b>	<b>Requirement of registration</b>
1	Any bidder from a country which shares a land border with India will be eligible to bid in this tender only if the bidder is registered with competent authority as per C below. In works contracts, including turnkey contracts, contractors shall not be allowed to subcontract works to any contractor from a country which shares a land border with India unless such contractor is registered with Competent authority. Relevant certificate to be submitted by bidder from a country which shares land border with India except for bidders to which Govt of India has extended lines of Credit or in which Govt of India has development projects, along with the offer as proof of registration with competent authority, failing which the offer will not be considered. A certificate is to be submitted by the bidder for compliance with the order referred above along with tender documents for consideration of offer (Wordings are as per Clause below). If such certificate given by a bidder whose bid is accepted is found to be false, this would be a ground for immediate termination and further legal action in accordance with law.
2	<b>Wordings of certificate to be submitted along with tender documents</b>
	I have read the clause regarding restrictions on procurement from a bidder of a country which shares a land border with India. I hereby certify that this bidder is not from such a country or, if from such a country, has been registered with the competent authority. I hereby certify that this bidder fulfils all requirements in this regard and is eligible to be considered. (Evidence of valid registration by the competent authority shall be attached wherever applicable)
2	<b>Wordings of certificate to be submitted along with tender documents for Works involving possibility of subcontracting</b>
	I have read the clause regarding restrictions on procurement from a bidder of a country which shares a land border with India and on subcontracting to contractors from such countries. I certify that this bidder is not from such a country or if from such a country has been registered with the competent authority and will not subcontract any work to a contractor from such countries unless such contractor is registered with the competent authority. I hereby certify that this bidder fulfils all requirements in this regard and is eligible to be considered (Evidence of valid registration by the competent authority shall be attached wherever applicable)
<b>B</b>	<b>Validity of registration</b>
1	Registration should be valid at the time of submission of bids and at the time of Acceptance of bids. In respect of supply otherwise than by tender, registration should be valid at the time of placement of order. If the bidder is validly registered at the time of acceptance /order placement, registration shall not be a relevant consideration during contract execution.
<b>C</b>	<b>Competent authority and Procedure for registration</b>
1	The competent authority for the purpose of registration under the order shall be Registration committee constituted by the Department of Promotion of Industry and Internal Trade (DPIIT). Details of the committee and procedure for registration and restrictions shall be as per Ann I of the Order – Public Procurement no 1 dt 23.7.2020 issued by Ministry of Finance, department of Expenditure.





<b>D</b>	<b>Definition of Bidder and Bidder from a country sharing land border with India</b>
1	Bidder is defined as any person or firm or company including any, member of a consortium or joint venture, every artificial, juridical person not falling in any of the descriptions of bidders stated here in before, including any agency, branch or office controlled by such person, participating in a procurement process.
2	"Bidder from a country which shares a land border with India "for the purpose of this Order means:- a) An entity incorporated, established or registered in such a country; or b) A subsidiary of an entity incorporated, established or registered in such a country; or c) An entity substantially controlled through entities incorporated ,established or registered in such a country; or d) An entity whose beneficial owner is situated in such a country; or e) An Indian (or other) agent of such an entity; or f) A natural person who is a citizen of such a country ;or g) A constitution or joint venture where any member of the consortium or joint venture falls under any of the above.
3	<b>Type of business entity</b> (Private Limited Company / Public Limited Company / Sole Proprietorship / One Person Company / Partnership / Limited Liability Partnership / Joint Venture / Trust/ NGO)In case of incorporated entity-to attach certificate of incorporation
	<b>Beneficial Owners</b> –as defined in the Department of Expenditure Order (Public Procurement No.1) issued vide No. F.No.6/18/2019-PPD dated 23 <sup>rd</sup> July, 2020.Details of all beneficial owners having entitlement of more than 01% of shares orCapital or profit to be given, in the format as given in Annexure-I duly certified byPracticing Chartered Account in India.

<b>Tender condition- Preference to Make in India</b>	
A	Purchase preference in accordance with Public procurement (Preference to Make in India Order – 2017) Order from Department of Promotion of Industry and Internal Trade P-45021/2/2017/-B.E-Ildt,4.6.2020 and as amended from time totime shall be applicable as per below
1	In the procurement of all goods/services/works in respect of which there is sufficient local capacity /local competition, only Class I Local suppliers shall beeligible to bid irrespective of purchase value
2	In the procurement of all goods/services /works which are not covered as above and with estimated value of purchase less than Rs 200.0 Crores, only Class I localSuppliers along with Class II local suppliers shall be eligible to bid.
	<b>Purchase preferences for Class I local suppliers</b>
B	In the procurement of goods/works covered under 2 above and which are divisible in nature, Class I local supplier shall be eligible for Purchase preference over ClassII / Non local supplier as per following
1	If L1 bid is not a Class I local supplier, 50% of the order quantity shall be awardedto L1. Thereafter the lowest bidder among Class I local supplier will be invited tomatch the L1 price for the remaining 50% quantity subject to Class I local supplierquoted price falling within 20% margin. Contract for that quantity shall be awardedto such Class I local supplier subject to matching L1 price. In case such lowesteligible Class I local supplier fails to match L1 price or accept less than offered quantity , next higher Class I local supplier within 20% margin shall be invited tomatch the L1 price for the remaining qty and so on . If some quantity is leftuncovered on Class I local supplier, such balance quantity shall be ordered on L1bidder.

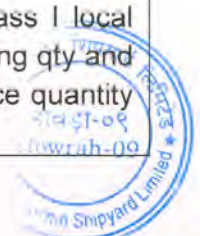

2	For procurements that are not divisible in nature and in procurement of services evaluated on price alone, Class I local supplier shall get purchase preference over Class II/Non local supplier as per below
3	If L1 is not a Class I local supplier, lowest bidder among Class I local supplier will be invited to match L1 price subject to Class I local supplier quoted price falling within 20% of L1 price and contract will be awarded to such Class I local supplier, subject to matching L1 price. In case such lowest eligible Class I local supplier fails to match L1 price, procedure same as para 3 above will be opted. In case none of Class I local suppliers within 20% margin matches L1 price, contract shall be awarded to L1 bidder. The purchase preference as above will be only for Class I local supplier and Class II local supplier will not be eligible for any Purchase preference
C	Local content requirement to categories a supplier as Class I/Class II/Non local supplier shall be as per below. Definition of local content shall be as per order dt 4.6.2020 i.e amount of value added in India which shall be the total value of the item procured (excluding net domestic indirect taxes) minus the value of import content in the item (including all customs duties) as a proportion of total value in percentage.
1	Class I-Local content equal to or greater than 50%
2	Class II-Local content greater than 20%, less than 50%
3	Non local-Local content less than 20%
<b>D</b>	<b>Declaration of local content</b>
1	Class I local supplier /Class II local supplier at the time of tender shall indicate % of local content and provide self certification that offered item shall meet the local content requirement for Class I/Class II as applicable including details of locations at which local value addition is made.
2	In case of procurement for a value in excess of Rs 10.0 Crores Class I/Class II local supplier is to provide a certificate from statutory auditor/cost auditor (for companies) /practicing cost accountant/ Chartered accountant (suppliers other than companies) indicating % of local content
3	Verification of the Certificates issued by the bidder shall be carried out by HCSL on random basis. False declarations will attract actions as stipulated in the order referred, including other actions as permissible by law.
4	Exemption is applicable from provisions of order for purchases with estimated values less than Rs 5.0 lakhs
5	Notwithstanding above, exemptions for meeting local content as per relevant Clause of order dt 4.6.2020 and as amended from time to time shall apply.



**SPECIAL INSTRUCTIONS FOR SINGLE BID SYSTEM**

**1. MODE OF SUBMISSION OF TENDERS**

Tenders should be submitted in ONE Single sealed covers superscripted in capital letters as "TECHNO-COMMERCIAL" & "PRICE" indicating the tender number, due date and name & address of the tenderer.

**2. TECHNO-COMMERCIAL PART SHOULD CONTAIN FOLLOWING DETAILS**

- a. Stamped and signed copy of all pages of **tender document and corrigenda (if any)** with all supporting document.
- b. Technical Specification check list as per **Annexure 2**.
- c. ***Signed Copy of unpriced Price bid (Annexure 3) (Price bid without price & with percentage of taxes & duties and details like quoted/Nil/included need to be mentioned for each line item.)***
- d. Techno-commercial check list as per **Annexure 6** with supporting documents if required.
- e. Vendor Details as per **Annexure 7**.
- f. NEFT mandate Form as per **Annexure 8**.
- g. List of Deviation (if Any) as per **Annexure 9**.
- h. Cost of Tender and EMD to be submitted along with Tender documents otherwise bid will be rejected, Bank Guarantee format as per **Annexure 10**.
- i. Security Deposit format as per **Annexure 11**.
- j. Self-Declaration as per **Annexure 12**.
- k. Legal Case Format as per **Annexure 13**.
- l. The average Annual Turnover of the bidder should be more than **Rs. 2.78 lakhs** during the last three preceding years. (Notarized Audited Balance sheets showing turnover, Profit & Loss account of the firm for the preceding 03 years (**Financial Year 2020-21, 2021-22, 2022-23**) should be submitted along with the application for prequalification) (to be supported by necessary documents and to be submitted along with technical bid).

**3. PRICE PART**

In Price Part as per Price Bid format (**Annexure 3**) should be signed and stamped kept in same cover and submitted strictly as per tender schedule.

**4. Validity: The offer should be valid for a minimum period of three (03) months of date of Bid opening.**

**5. HCSL reserves the right to alter, modify the scope of supply at their discretion.**

**6. The Techno-commercial part alone will be opened initially on the due date of tender. The price part will be opened only after evaluation of the Techno commercial part. Firms will be intimated the date of opening of the price part, whose Techno-commercial bid is acceptable, in due course. Tenderers shall not be allowed to attend the Techno commercial bid opening.**

**7. The Tenderer shall ensure that their Indian Agent is not representing any other suppliers for the same Tender. In other words, Indian Agents are not permitted to represent more than one firm for a particular Tender.**



8. Details of optional items, if any, should be indicated under separate heading in the technical bid and the respective price details should be given in the price bid.
9. After submission of quotation / price opening, no unsolicited correspondence will be entertained.
10. For Post Bid Queries 05 days' time will be given. If Queries are not closed within 05 days Bid will be rejected. Clarifications, either technical or commercial, should be submitted to points specially asked for only. The opportunity so given should not be used for correcting/changing/amending the data/conditions already submitted with the tender.
11. Price part should be submitted exactly in the Price Format as provided. Price should be quoted separately for each item shown in the format. Combining of figures against more than one item and ambiguous clauses will lead to rejection of the bid.
12. Check lists, both technical & commercial, duly filled & signed should be submitted along with "Techno-Commercial" bid. Non-receipt of this document may lead to rejection of the offer.
13. Offers should be clear and unambiguous. Incomplete/ambiguous offers are likely to be rejected.
14. The tender document to be submitted by the bidder in Duly signed and sealed format.
15. Bid Submission shall include Amendment / corrigendum / response to pre bid query duly signed and accept (if any).



**For Hooghly Cochin Shipyard Limited  
DGM (P&O)**

TECHNO-COMMERCIAL CHECK LIST				
SL. NO.	DESCRIPTION	COMPLIANCE		REMARKS
		YES	NO	
1.	Submission of Tender in one (1) part – Techno-commercial & Price			
2.	Delivery date confirmation to yards delivery schedule			
3.	Validity of offer – Three (03) months			
4.	Payment Terms - confirm your offered mode of payment 100% of the amount will be released after the completion of work against the order as per the scope of work, technical specifications and terms and conditions to the full satisfaction and acceptance of HCSL Officer-in-charge and on furnishing bill in triplicate.			
5.	The Prices offered should remain firm till the completion of delivery, in case the purchase order is placed with you.			
6.	Delivery of material at HCSL store including freight & insurance charges.			
7.	For indigenous suppliers: Have you quoted the rates for delivery at Hooghly Cochin Shipyard (For HCSL store) basis.			
8.	Have you considered Taxes, duties, levies, packing & forwarding etc., if any, in the offer.			
9.	Compliance with Pre-qualification criterion			
10.	L.D. payable as per relevant Clause in the General terms of enquiry.			
11.	Disputes in connection with contract subject to jurisdiction of courts at Kolkata India.			
12.	Termination of contract/Risk purchase as per relevant clause in the General terms of enquiry.			
13.	You should furnish appropriate certificate/paper. (Refer Annexure 2)			
14.	Confirm all other terms and conditions of enquiry are acceptable.			
15.	MSME/NSIC, if yes document required along with technical bid, in relevant sector			
16.	Vendor details to be submitted as per <b>Annexure 7</b> .			
17.	Supplier should be in the business of supplying any type of Anode/chemical/acids/alloys for the minimum three years if yes supporting documents to be submitted along with the technical bid.			
18.	Supplier should have minimum average annual turnover Rs. 2.78 Lakhs as on 31 <sup>st</sup> march 2023, 2022, 2021. if yes supporting document to be submitted along with technical bid			

**VENDOR DETAILS (to be submitted along with BID)**

<b>1</b>	Name of Bidder/Firm	
<b>2</b>	Registered office Address of Company/firm in Kolkata/Howrah: Local office address at Kolkata/Howrah (if held):	
<b>3</b>	Telephone No./Fax No./Mobile No:	
<b>4</b>	E-mail address:	
<b>5</b>	Names of the contact person & Designation:	1) 2) 3)
<b>6</b>	Type of Entity-Proprietorship/Partnership firm/company/NSIC/MSME Category etc. (Please attach registration certificate of Firm/Partnership agreement/proprietorship documents)	
<b>7</b>	Cost of Tender Details (DD No. Name of Bank)	NIL
<b>8</b>	EMD Details (DD No. Name of Bank)	NIL
<b>9</b>	PAN Card Number (Self-attested copy of PAN card has to be Submitted)	
	GST Registration No. (Self-attested copy has to be Submitted)	
<b>10</b>	Whether the agency has been blacklisted/de barred or given tender holiday or contract terminated before expiry of the contract period by any govt. autonomous bodies/organizations where bidder has provided services earlier due to deficiencies in service or misconduct etc.	Yes/No (Please tick as applicable) If yes, please furnish details on a separate sheet

- **Certified that the above information is true to the best of our belief and information.**

**Place:**

**Date:**

**Signature of Supplier/Authorized signature of firm/agency:**

**Name of Supplier or authorized signatory of firm/agency:**

**Designation:**

**NEFT MANDATE FORM**

**(ON THE LETTER HEAD OF THE COMPANY)**

**Electronic Payment Mandate Form**

(Mandate for receiving payments through RTGS/NEFT Hooghly Cochin Shipyard Ltd)

- 1) Vendor Name
- 2) Vendor Address with Phone No
- 3) Vendor Code
- 4) Permanent Account No. (PAN)
- 5) Particulars of Bank Account
  - a. Name of the Bank
  - 
  - b. Name of the Branch
  - 
  - c. Branch Code
  - d. NEFT Code of the Bank
  - e. City Name
  - f. Branch Location
  - g. Branch Telephone No.
  - h. Bank IFSC Code
  - i. 9-Digit MICR Code

**(Where MICR is starting with "0". Please take the correct code from your bank for proper identification of city, bank, branch)**

- i. Type of the Account (S.B Current or Cash Credit) with code (010/011/013)
  - j. Account Number (as appearing on the cheque book)
- 6 Email Address of Vendor
- 7 Date of Effect of RTGS/NEFT in your Bank

(Please enclose a cancelled un-signed cheque leaf to enable us to verify the details mentioned above)

We hereby declare that the particulars given above are correct and complete. If the transaction is delayed or lost because of incomplete or incorrect information, we would not hold the company responsible.

(.....)

Signature of Employee

Bank Certificate

We certify that \_\_\_\_\_ has an Account No. \_\_\_\_\_  
with us and we confirm that the details given above are correct as per our records.

Date:

Place:

(.....)  
Authorized official of Bank



COMPLIANCE STATEMENT- SPECIAL INSTRUCTIONS FOR TENDERERS AND TECHNICAL SPECIFICATION

PAGE 1 OF 1

Tender Name: **Procurement of Aluminium Anode for 2200T MPV at Hooghly Cochin Shipyard Limited, Nazirgunge Unit, Howrah (Detailed specification is enclosed separately)**

TENDER NO: HCSL/OPS/SB/TEN/219/2023-24, Dt.- 14.02.2024

We hereby confirm and truly declare that our Offer / Bid No. ....dated .....is in full compliance with the documents issued against the Tender No. -----dated -----, except for the deviations listed below:

**LIST OF DEVIATIONS (HCSL reserves the right to reject offers with deviations)**

Sl. No.	Description / Tender Reference	Reasons for Deviation

Name of tenderer:

Date:

Name & Designation

Seal & Signature

(Company Seal)

**Form of bank Guarantee towards EMD**  
(On stamp paper of value Rs. 200/-)

This deed of GURANTEE made on ..... day of .....Two thousand Eighteen between HCSL on the one part and ..... (Name and address of the bank) of the other part is as follows: -

In consideration of the HCSL having allowed M/s..... (Hereinafter referred to as 'the Supplier') to submit Tender No..... to them without Earnest Money according to the conditions of such Tender Notification.

We..... (here enter the name of 'the Bank') a Company incorporated under the .....Act and having its registered office at .....(hereinafter referred to as 'the bank') undertake to pay to HCSL on demand at Kolkata the sum of money payable as Earnest Money in respect of the Tender No.....made by the Supplier, in case the Supplier withdraws the tender before the date of firmness stipulated or when the tender is accepted by or on behalf of the HCSL the Supplier makes default in furnishing the Security Deposit or in entering into an agreement as required by the HCSL or otherwise commits any breach of the terms and conditions of the tender.

We, .....Bank Guarantee to pay the amount due and payable under this guarantee without any demur merely on demand from the HCSL. Any such demand made on the Bank shall be conclusive as regards the amount due and payable by the Bank under this guarantee. The liability of the surety shall be restricted to Rs .....(Rs.....only)

This guarantee shall not be avoided, released or affected by any variation in the terms of the tender, acceptance or the contract between the Contractor and the HCSL or any neglect indulgence or forbearance by the HCSL.

This guarantee shall remain in full force and effect during the period that would be taken for the finalization of the tender and till the HCSL certifies that the terms and conditions of the said tender have been fully and properly carried out by the Supplier and accordingly discharges this guarantee or for Six Months from the date of issue of this guarantee whichever is earlier. A notice of the claim under this guarantee may be served on the Bank within Six Months after the said period in which case the same shall be enforceable against the Bank notwithstanding the fact that the same is enforced after the expiry of the said period.

The decision of the CEO, HCSL as to whether the occasion or the ground has arisen for the demand of the surety form Bank shall be final. The HCSL shall be at liberty to act as though the Bank were the principal debtor.

We, the said Bank lastly undertake not to revoke this guarantee during its currency except with the previous consent of the HCSL in writing and agree that any change in the constitution of the said contractor or the said Bank shall not discharge our liability hereunder.

In witness whereof we have hereunto set our hand and seal this, ..... day  
.....of.....Two thousand and  
.....

Place:

Date:

**BANK GUARANTEE IN LIEU OF SECURITY DEPOSIT/  
WARRANTY GUARANTEE**

To

HOOGHLY COCHIN SHIPYARD LTD

(Govt. of India Enterprise,)

Satyen Bose Road,

Danesh SK Lane (PO),

Nazirgunge, Howrah,

West Bengal - 711109.

WHEREAS.....(Name & Address of Supplier)  
(hereinafter called " **the Supplier**") has undertaken , in pursuance of  
Contract.....No.....Dated:.....  
...to execute.....(Name of Contract and brief description of  
works)(hereinafter called " **the Contract**").

AND WHEREAS it has been stipulated by **HOOGHLYCOCHIN SHIPYARD LTD**  
(The Buyer – hereinafter called "**HCSL**") in the said contract that the Supplier shall furnish  
**HCSL** with a Bank Guarantee for the sum specified therein as security for compliance  
with the Supplier's obligations in accordance with the Contract.

AND WHEREAS we have agreed to give the Supplier such a Bank Guarantee.

NOWHEREFORE we.....(Name of the Bank) having its Head Office  
at.....(Address of Head Office)and acting through its branch office  
at.....(Address of the executing branch)(hereinafter called " the Bank")  
hereby affirm that we are the Guarantor and responsible to **HCSL**, on behalf of the Supplier  
upto a total of.....(amount of Guarantee) in words).

We, the bank, hereby irrevocably undertake to pay you any amount not exceeding in total  
the Guarantee Amount upon receipt by us of your demand in writing accompanied by the  
following documents:

1. Your signed statement certifying that the Supplier is in breach of his  
obligation(s)under the Contract and the respect in which the Supplier is in breach.
2. Your signed statement certifying that the Supplier has been given a prior written  
notice by email from you to make good the aforesaid breach and that the Supplier  
still failed to fulfill the Contract within 30 days of such notice. A copy of such  
notice given by email to the Supplier shall be attached to the demand for payment.

Any demand for payment should contain your authorized signatures which must be authorized by your bankers or by a notary public.

We, the Bank, further agree that no change or addition to or other modification of the terms of the Contract or of the Works to be performed there under or of any of the Contract documents which may be made between **HCSL** and the Supplier shall in any way release us from any liability under this guarantee, and we hereby waive notice of any such change, addition or modification. We, the Bank, further agree that any change in the constitution of the said contractor or the said bank shall not discharge our liability hereunder.

**Notwithstanding** anything contained herein:

- 1 | Our liability under this Bank Guarantee shall not exceed .....(only).
  
2. This Bank Guarantee shall be valid upto (date)and
  
3. We are liable to pay the guaranteed amount or any part thereof under this bank guarantee only and only if **HCSL** serve upon us a written claim or demand on or before.....(validity date).

Any demand for payment under this guarantee must be received by us at this office during working hours on or before the validity date. Should we receive no claim from you by the validity date, our liability to you will cease and the guarantee will definitely become null and void whether returned to us or not.

Yours truly,

Signature and seal of the

guarantor:.....

Name of

Bank:.....

.....

Address:.....

Date:.....

<sup>1</sup>An amount shall be inserted by the Guarantor, representing the percentage of the Contract Price specified in the Contract and denominated in respective Dollars / Indian Rupees/Other Currency.

**Self-Declaration to be given by the bidder in Letter head**

Bid's Reference No. & Date:

Bidder's Name & Address:

Person to be contacted:

Designation:

Telephone No.:

Fax No.:

Email:

1. We do hereby declare that we have not been debarred/black listed by HCSL or by any of the Public Sector Undertaking or Government department etc.

2. If HCSL finds that, we have been blacklisted/ debarred by any of the Public Sector Undertaking or Government department, and then HCSL can reject the offer or terminate the contract at any point of time. In such case, we are aware that, EMD, security deposit, performance guarantee etc will be forfeited by HCSL. Further we are confirming herewith that, any loss that has happened to HCSL due to this will be compensated by us.

For and on behalf of the firm

(Firms Name & Address)

(Signature of Authorized Signatory)

Name:

Designation

Phone No.:

Seal:

Date: .....

Place:.....

(Sample Format)

Details of legal cases pending against the firm for the last five years

L. NO.	ORGANISATION AGAINST WHOM THE LITIGATION IS INVOLVED	BRIEF DETAILS OF DISPUTE	AMOUNTS INVOLVED (Rs. ....)	PRESENT STATUS	Remarks

SIGNATURE OF BIDDER